



7523 and 7550 Console Drive



77301-23 Wall Mount Controller with 77301-21 Pump Drive and 77301-22 Benchtop Controller

OPERATING MANUAL:
PUMP DRIVES

NOTICE D'UTILISATION :
**ENTRAÎNEMENTS DE
POMPES**

BEDIENUNGSANLEITUNG:
PUMPENANTRIEBE

MANUAL DE OPERACIÓN:
**PROPULSORES DE
BOMBAS**

MANUALE DI ISTRUZIONI:
AZIONAMENTI

MANUAL DE OPERAÇÃO:
**ACIONADORES DE
BOMBA**

取扱説明書：
ポンプ駆動システム

操作手册
泵控制台

Model Nos.	975-3000
Modèles n°	975-3010
Modellnummern	975-3100
Números de modelo	975-3100
Modelli n°	975-3100
Modelos N°	
型番	
型号	

A-1299-0996
Edition 03

PUMP DRIVES—MODEL NOS.

TYPE	SYSTEM	PUMP DRIVES	CONTROLLER
Benchtop Modular	77301-20	77301-21	77301-22
NEMA Modular	77301-30	77301-21	77301-23
Std. Console, 600 rpm	7523-60	—	—
Std. Console, 100 rpm	7523-70	—	—
Console w/SIO, 600 rpm	7550-30	—	—
Console w/SIO, 100 rpm	7550-50	—	—

ENTRAÎNEMENTS DE POMPES—MODÈLES N°

TYPE	SYSTÈME	ENTRAÎNEMENTS DE POMPES	CONTRÔLEUR
Modulaire sur banc	77301-20	77301-21	77301-22
Modulaire NEMA	77301-30	77301-21	77301-23
Console standard, 600 tr/mn	7523-60	—	—
Console standard, 100 tr/mn	7523-70	—	—
Console avec E/S série, 600 tr/mn	7550-30	—	—
Console avec E/S série, 100 tr/mn	7550-50	—	—

PUMPENANTRIEBE—MODELLNUMMERN

TYP	SYSTEM	PUMPENANTRIEBE	CONTROLLER
Tischmodell, modular	77301-20	77301-21	77301-22
NEMA, modular	77301-30	77301-21	77301-23
Std. Konsole, 600 U/min	7523-60	—	—
Std. Konsole, 100 U/min	7523-70	—	—
Konsole mit SIO, 600 U/min	7550-30	—	—
Konsole mit SIO, 100 U/min	7550-50	—	—

PROPULSORES DE BOMBAS—NÚMEROS DE MODELO

TIPO	SISTEMA	PROPULSORES DE BOMBAS	CONTROLADOR
Modular de banco	77301-20	77301-21	77301-22
Modular NEMA	77301-30	77301-21	77301-23
Consola est., 600 rpm	7523-60	—	—
Consola est., 100 rpm	7523-70	—	—
Consola con SIO, 600 rpm	7550-30	—	—
Consola con SIO, 100 rpm	7550-50	—	—

AZIONAMENTI—MODELLI N°

TIPO	SISTEMA	AZIONAMENTI	CONTROLLER
Modulare da banco	77301-20	77301-21	77301-22
Modulare NEMA	77301-30	77301-21	77301-23
Console standard, 600 giri al minuto	7523-60	—	—
Console standard, 100 giri al minuto	7523-70	—	—
Console con ingresso e uscita seriali, 600 giri al minuto	7550-30	—	—
Console con ingresso e uscita seriali, 100 giri al minuto	7550-50	—	—

ACIONADORES DE BOMBA - MODELOS NÚMEROS

TIPO	SYSTEMA	ACIONADORES DE BOMBA	CONTROLLER
Modular, de Bancada	77301-20	77301-21	77301-22
Modular NEMA	77301-30	77301-21	77301-23
Console Standard, 600 r / min	7523-60	—	—
Console Standard, 100 r / min	7523-70	—	—
Console com Entr. / Saída Serial, 600 r / min	7550-30	—	—
Console com Entr. / Saída Serial, 100 r / min	7550-50	—	—

ポンプ駆動システム — 型番

製品名	システム	ポンプ駆動システム	コントローラ
ベンチトップモジュール	77301-20	77301-21	77301-22
NEMA モジュール	77301-30	77301-21	77301-23
標準コンソール (600 r/min)	7523-60	—	—
標準コンソール (100 r/min)	7523-70	—	—
コンソール SIO シリーズ (600 r/min)	7550-30	—	—
コンソール SIO シリーズ (100 r/min)	7550-50	—	—

泵控制台 — 型号

类型	系统	泵控制台	控制器
顶部模件	77301-20	77301-21	77301-22
NEMA 模件	77301-30	77301-21	77301-23
标准控制 (600 rpm)	7523-60	—	—
标准控制 (100 rpm)	7523-70	—	—
SIO 控制 (600 rpm)	7550-30	—	—
SIO 控制 (100 rpm)	7550-50	—	—

TABLE OF CONTENTS

Title	Page
SAFETY PRECAUTIONS	iv
INTRODUCTION	1
CONTROL/DISPLAY FUNCTIONS	1
SETUP AND DRIVE OPERATION	2
Automatic Start Enable/Disable	2
CALIBRATION	2
Maximum Flow Rate (“OTH(ER)” Tubing)	2
DISPENSE/COPY	3
Keypad Lockout Enable/Disable	3
REMOTE CONTROL	3
Remote Control Setup	3
TROUBLESHOOTING AND MAINTENANCE	5
Fuse Replacement	5
Troubleshooting	6
Cleaning	8
Replacement Parts and Accessories	8
SPECIFICATIONS	8
WARRANTY	10
PRODUCT RETURN	10
TECHNICAL ASSISTANCE	10
APPENDIX A	11

SAFETY PRECAUTIONS

DANGER: *High voltages exist and are accessible in the Digital PWM BLDC Drive. Use extreme caution when servicing internal components.*



WARNINGS: *Tubing breakage may result in fluid being sprayed from pump. Use appropriate measures to protect operator and equipment.*



Turn drive off before removing or installing tubing. Fingers or loose clothing could get caught in drive mechanism.

CAUTION: *Power must be turned off before connecting the external remote control cable to prevent damage to the drive.*



CAUTION: *To avoid electrical shock, the power cord protective grounding conductor must be connected to ground. Not for operation in wet locations as defined by EN 61010-1.*



Explanation of Symbols

CAUTION: *Risk of Danger. Consult Operator’s manual for nature of hazard and corrective actions.*



CAUTION: *Risk of crushing. Keep fingers away from rotor while pump is in operation. Stop pump before loading or unloading tubing.*



CAUTION: *Hot Surface. Do not touch.*



CAUTION: *Risk of electric shock. Consult Operator’s manual for nature of hazard and corrective actions.*



WARNING: PRODUCT USE LIMITATION

This product is not designed for, nor intended for use in patient connected applications; including, but not limited to, medical and dental use, and accordingly has not been submitted for FDA approval.

INTRODUCTION

The Digital PWM BLDC Drive controls the speed of MASTERFLEX® L/S® Pump Heads to provide flow rates from 0.10 to 3400 mL/min.

Mount up to 2 (600 rpm) or 4 (100 rpm) MASTERFLEX® L/S® Pump Heads and all MASTERFLEX-compatible pump heads.

CONTROL/DISPLAY FUNCTIONS

Press keys to activate function.

Use up/down (▲, ▼) arrow keys to correct/change a flashing display.

Press any key to enter new values.

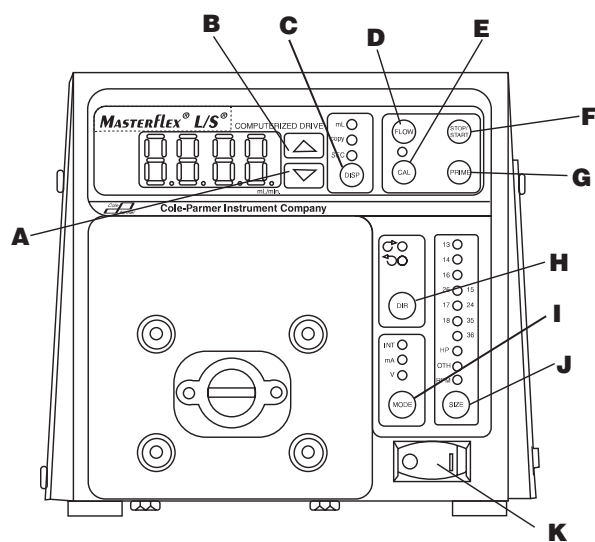

7523 and 7550

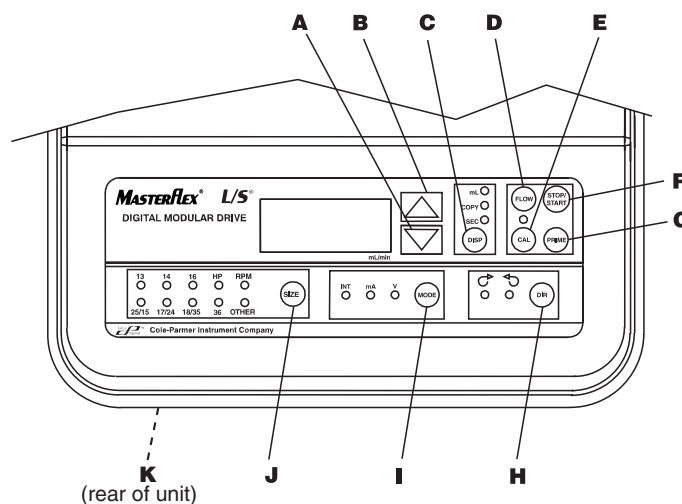

(rear of unit)

77301

- A. DOWN ARROW (DECREMENT)**—Decrease value of a flashing display.
- B. UP ARROW (INCREMENT)**—Increase value of a flashing display.
- C. DISPENSE/COPY**—Select dispensed volume, number of copies of a dispensed volume, or the interval between dispenses.
- D. FLOW CONTROL**—Set flow rate for selected tubing size. To change flow rate, press ▲ or ▼ arrow keys. (If pump is running, its speed will change with new settings.)
- E. CAL CONTROL**—Refine built-in calibration, using a measured volume.
- F. STOP/START**—Stop/Start motor.
- G. PRIME**—Run pump at full speed to fill or clear lines.
- H. DIRECTION**—To change motor direction.
- I. MODE SELECT**—INT for internal control; mA for remote current control; V for remote voltage control.
- J. SIZE**—Select tubing size.
- K. POWER SWITCH**—All settings are retained in memory.

SETUP AND DRIVE OPERATION

1. On 77301 connect Motor Cable plug to mating receptacle on the Controller.
2. Mount pump head and load tubing. (See pump head manual.)
3. Connect power cord to Controller and grounded power line outlet.
4. Turn pump on and select tubing SIZE.

NOTE: If CAL LED is lit, that tubing size has been previously field calibrated. If LED is not lit, the drive is operating with the built-in factory calibration. To clear a field calibration, press and hold the CAL switch until the CAL light goes out. This will take about 3 seconds. To recalibrate for better accuracy, see Calibration section.

5. MODE selection (INT, mA, V).
6. Select motor DIRection (CW or CCW).
7. PRIME and CALibrate the pump (if required).
8. Press FLOW key and watch display to set the flow rate with UP/DOWN (▲, ▼) arrow keys.
9. Press STOP/START key to begin pumping.

NOTE: Normally, pump will not restart automatically after a brownout or powerout condition.

Automatic Start Enable/Disable

Press and hold STOP/START on power-up. After five (5) seconds, display will change to all dashes. Then, while holding STOP/START, press PRIME five (5) times. Display will flash "ON" or "OFF". Use UP/DOWN (▲, ▼) arrow keys to set automatic start option. Press any other key to exit. When "ON" is selected, pump will start automatically at power-up if it was "ON" when powered down.

CALIBRATION

***Use only MASTERFLEX precision tubing with MASTERFLEX pumps to ensure optimum performance.
Use of other tubing may void applicable warranties.***

1. Select correct tubing size and flow rate.
2. Press CAL, calibration volume appears.
3. Press STOP/START, the pump will use its stored memory to dispense the specified calibration sample quantity. The pump will stop automatically.
4. Weigh/measure the sample.
5. Use UP/DOWN (▲, ▼) arrow keys to correct the flashing display.

NOTE: If the adjusted calibration is too great, "Err" will appear in the display. If this occurs, press the CAL control and repeat the calibration procedure. The microprocessor will retain one special calibration value per tubing size, even when power is turned off. The next calibration will replace the existing value.

6. Press SIZE to exit the calibration cycle.

Maximum Flow Rate ("OTH(ER)" Tubing)

1. To set the maximum flow rate for non-standard pump heads or tubing sizes, press CAL, then FLOW. The maximum flow rate will then flash on the display.
2. Use UP/DOWN (▲, ▼) arrow keys to set desired flow rate.
3. Press SIZE to exit.

DISPENSE/COPY

A first press of the DISP key results in the last entered dispense volume being displayed. The "mL" annunciator will illuminate and flash. The UP/DOWN (▲, ▼) keys are used to change the dispense volume, if desired. The STOP/START key then initiates delivery of the set volume. The amount remaining to be dispensed will be displayed during countdown. The dispense function is exited by pressing any key except UP (▲), DOWN (▼), DISP, or STOP/START.

A second press of the DISP key causes the COPY annunciator to illuminate and flash. The STOP/START key is then used to deliver the desired volume without the need to know the volume in specific units. A third press of the DISP key enters the volume dispensed. The COPY annunciator stops flashing. The STOP/START key is then used to initiate delivery of the copied volume. The number of copies dispensed will be displayed after each dispense. The maximum number of copies is 9999. The STOP/START key is used to pause the copy dispense during dispensing; copy dispense can then be continued using the STOP/START key.

A fourth press of the DISP key results in the last entered interval between dispenses being displayed. The SEC annunciator will illuminate and flash. The UP/DOWN (▲, ▼) keys are used to change the time between dispenses, if desired, from 1 to 9999 seconds. The STOP/START key then initiates delivery of the set volume, with the drive automatically initiating a new dispense after each timeout. The remaining time will be displayed during countdown. The STOP/START key is used to stop the dispense cycle. A time of 0 seconds (default) will require initiation of each dispense through the STOP/START key or the Remote STOP/START contact closure.

Pressing the DISP key a fifth time exits this mode.

Keypad Lockout Enable/Disable

Press and hold FLOW. After five (5) seconds, display will change to all dashes. Then, while holding FLOW, press PRIME five (5) times.

REMOTE CONTROL

Selectable input (0–20 mA, 4–20 mA, 0–10V DC)

±0.5% linearity control

±50V common mode range

STOP/START; CW/CCW; PRIME via contact closure

Remote Control Setup

1. Place the power switch in the off position.

CAUTION: *Power must be turned off before connecting the external remote control cable to prevent damage to the drive.*



2. Connect the cable from the external remote control to the DB-15 receptacle on the rear panel. On wash-down units, connect to the mating receptacle on the bottom panel.

3. Select type of remote control input and output required as follows:

- a. Press and hold the MODE control while turning the power switch to the on position. After two seconds, release the MODE control. The initial display will show: "inP". After two seconds, the display shows either 0–20 or 4–20.

NOTE: Press the UP (▲, increment) or DOWN (▼, decrement) arrow keys to select between 4–20 and 0–20 for current loop control.

- b. Press the MODE control again. The initial display will show: "out". After two seconds, the display shows either 0–10 or 0–20 and 4–20.

NOTE: Press the UP (▲, increment) or DOWN (▼, decrement) arrow keys to select between 4–20 or 0–20 and 0–10 for current loop or voltage output.

4. Press the MODE control to select mode of operation. The LEDs indicate the selected mode. Select either mA or V.

NOTE: If using only remote STOP/START, PRIME and/or CW/CCW, the MODE control can be set to any of the three positions.

5. To adjust the voltage or current scaling for other than zero to full scale, press and hold the MODE key while pressing the FLOW key. This display will show "LO" for 2 seconds and then a flow rate. Use the UP/DOWN (▲, ▼) arrow keys to set the minimum control level. Press the FLOW key again. The display will show "HI" for 2 seconds and then a flow rate. Use the UP/DOWN (▲, ▼) arrow keys to set the maximum control level. Press any other key to exit. The same scaling will be used for both input and output levels.

NOTE: Tubing size should be selected before adjusting the voltage or current scaling.

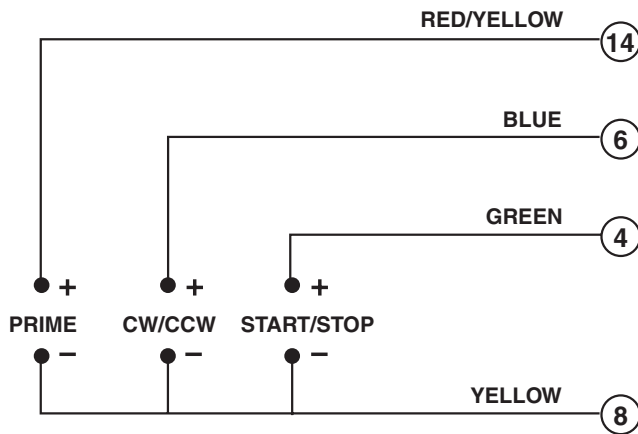
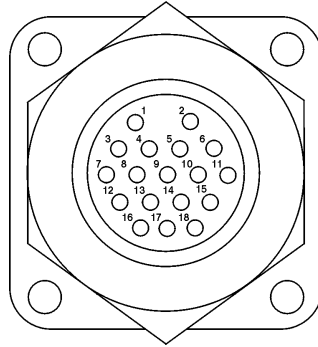

NOTE: Colors are those of Remote Cable, Catalog number 77300-32.

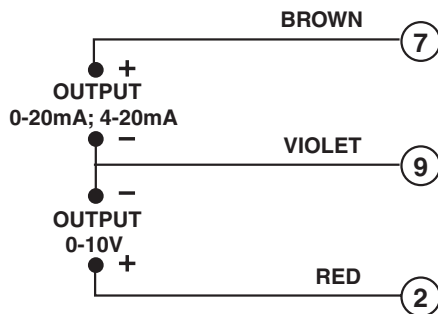
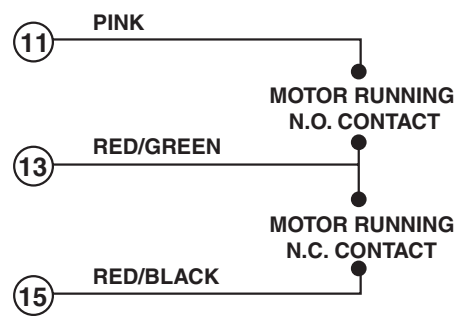
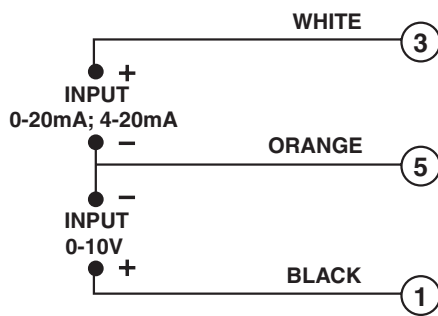
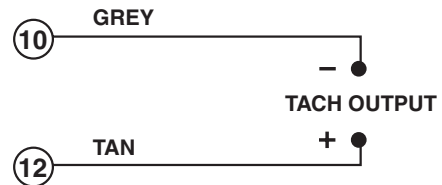

DB-15 pin configuration/with wiring scheme

- A. STOP/START
- B. CW/CCW
- C. OUTPUT 0-20mA; 4-20mA
- D. INPUT 0-20mA; 4-20mA
- E. INPUT 0-10V
- F. OUTPUT 0-10V
- G. TACH OUTPUT
- H. PRIME
- I. MOTOR RUNNING N.O. CONTACT
- J. MOTOR RUNNING N.C. CONTACT

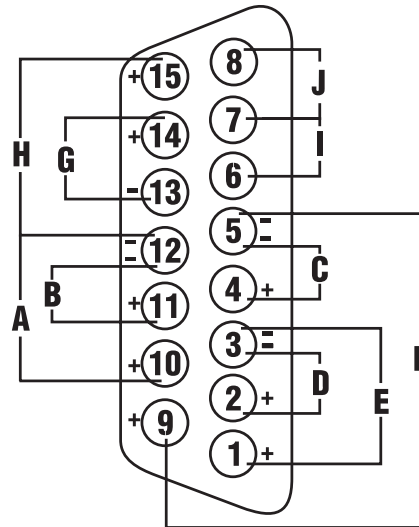

7523, 7550 and 77301-22

TROUBLESHOOTING AND MAINTENANCE

Fuse Replacement

1. Place the power switch in the off position.
2. Disconnect the AC power input line cord from the receptacle.
3. Remove and check the fuse and replace if defective.
4. Reconnect the AC power input line cord to the receptacle.

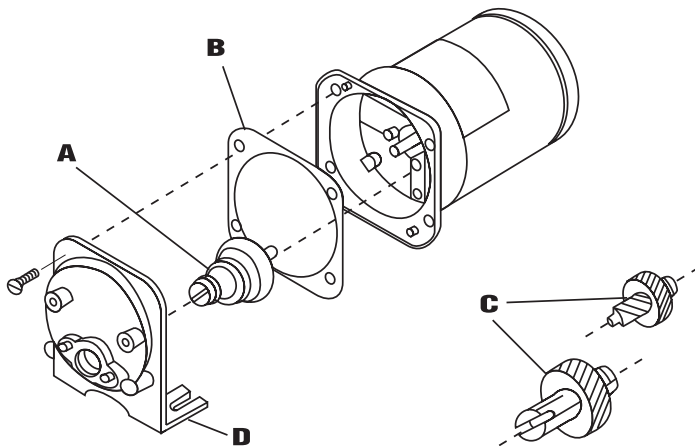

- A. 6-600 RPM GEAR ASSEMBLY (included in service kit 07553-06 - Console Drive and 77300-01 - Modular Drive)
- B. GASKET
- C. 1-100 RPM GEAR SET (included in service kit 07553-08)
- D. GEAR CASE COVER ASSEMBLY

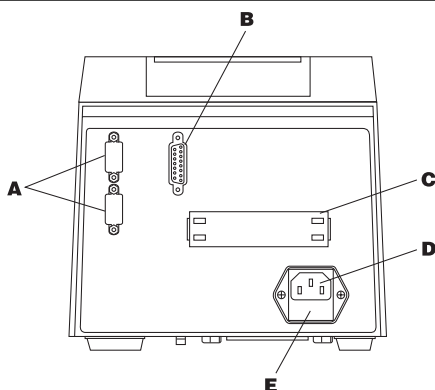

REAR PANEL – 7550-30, -50

- A. IN-RS-232C IN-CONNECT CABLE FROM HOST COMPUTER
OUT-RS-232C OUT-CONNECT CABLE TO NEXT PUMP DRIVE
- B. EXTERNAL RECEPTACLE
- C. AUX 1 OUT; AUX 2 OUT, AUX IN
- D. IEC 320 POWER ENTRY MODULE
- E. T3.15A FUSE

⚠ **CAUTION:** Do not substitute.

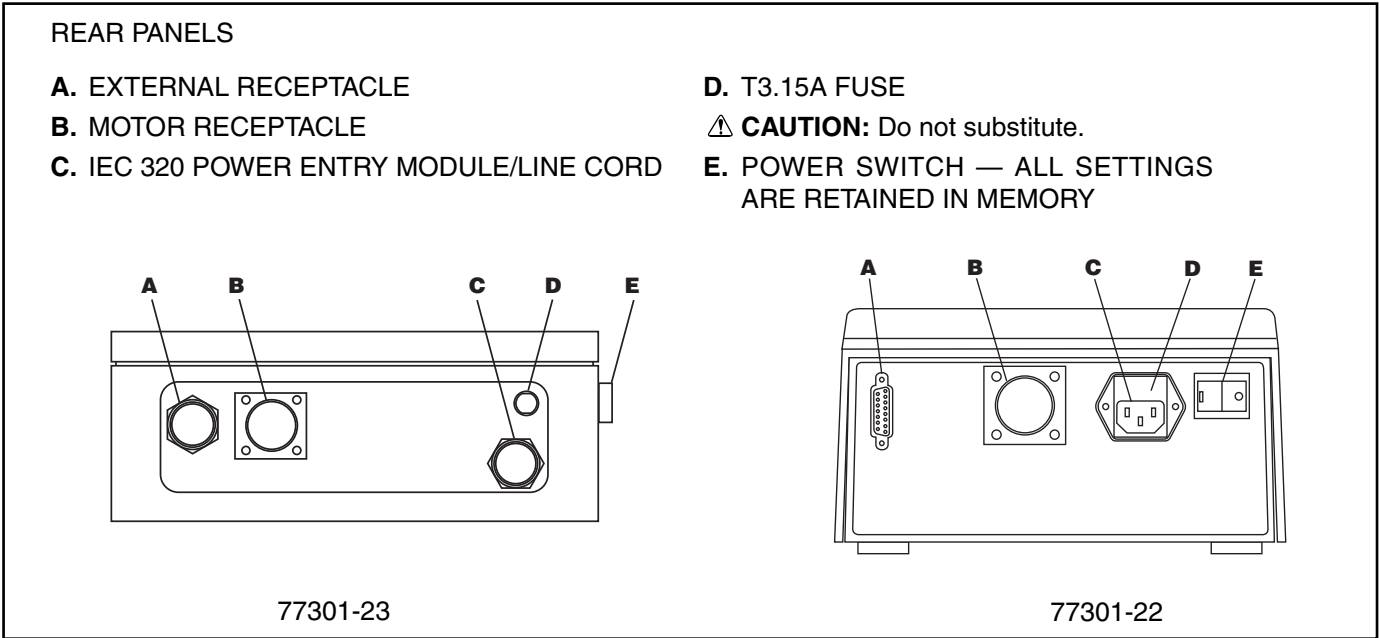
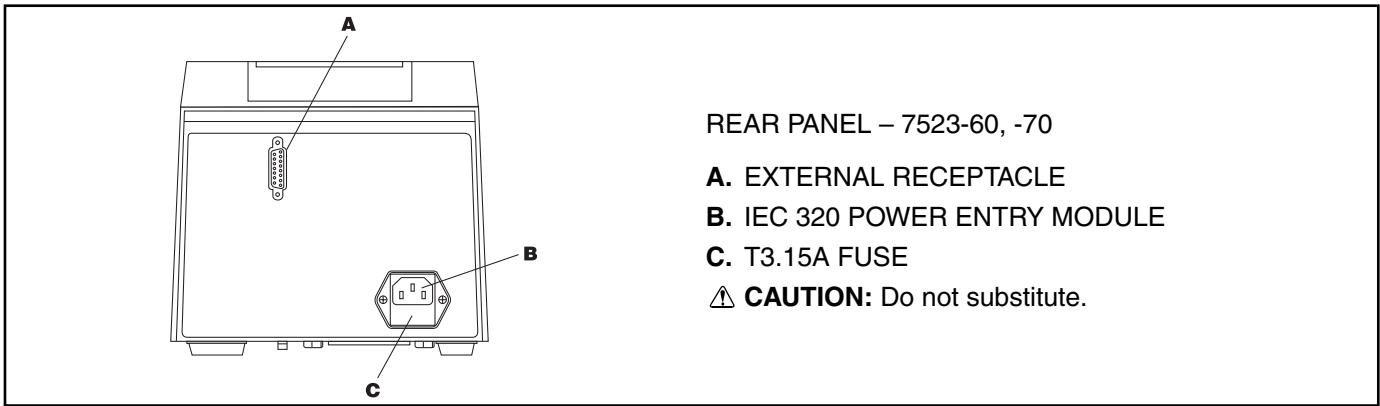

Troubleshooting

SYMPTOM	CAUSE	REMEDY
A. Motor does not rotate. Display does not light.	A. No power.	<ol style="list-style-type: none"> 1. Check fuse and replace if defective. 2. Check that unit is plugged into a live line. 3. Check connection of power cord. 4. Check the line cord for continuity and replace if defective. 5. Return for servicing.
B. Motor does not rotate. Display lights.	B1. Defective remote control.	<ol style="list-style-type: none"> 1. Place power switch in off position. 2. Check that remote cable connector is inserted fully into the receptacle. 3. If motor still does not rotate, select INT with the MODE control and press the STOP/START control. 4. If the motor rotates, replace the remote control with similar unit. If motor does not rotate, return drive for servicing.

Troubleshooting (cont.)

SYMPTOM	CAUSE	REMEDY
B. (cont.) Motor does not rotate. Display lights.	B2. MODE control not properly set.	<ol style="list-style-type: none"> 1. Check that the MODE control is set to INT for operation with front panel control or to mA or V for operation with remote control. 2. If motor will not rotate, return for servicing.

If an **error message** is displayed, refer to the following list for possible corrective actions you can take. If these do not correct the problem, contact your dealer.

ERROR MESSAGE	CAUSE	REMEDY
"Err 2"	Motor over-speed	<ol style="list-style-type: none"> 1. Clear by pressing any key. 2. Check for proper tube loading and pump operation. 3. Return unit for repair if the error persists.
"Err 3" "Err 5" "Err 12"	Overload	<ol style="list-style-type: none"> 1. Clear by pressing any key. 2. Check for proper tube loading and pump operation. 3. Return unit for repair if the error persists.
"Err 7"	Bad data. Operator parameters set to default values.	<ol style="list-style-type: none"> 1. Clear by pressing any key. 2. Reprogram operator parameters. 3. Return unit for repair if the error persists.
"Err 10" "Err 11"	Voltage out of range	<ol style="list-style-type: none"> 1. Clear by pressing any key. 2. Check that AC line voltage is within specified voltage ranges. 3. Return unit for repair if AC line voltage is correct and the error persists.
"Err 14"	Over temperature	<ol style="list-style-type: none"> 1. Check for heat sources or obstructions to cooling. 2. Check for proper tube loading and pump operation. 3. Allow unit to cool. Clear by pressing any key. 4. Return unit for repair if no cause for overheating is found and the error persists.
All other errors	Internal error or failure.	<ol style="list-style-type: none"> 1. Clear (if possible) by turning power off and on. 2. Return unit for repair if the error persists.

Cleaning

Keep the drive enclosure clean with mild detergents. Do not immerse.

Replacement Parts and Accessories

Description	Part Number
Fuse-T3.15A	77500-25
Gear Service Kit (600 rpm - Console)	07553-06
Gear Service Kit (600 rpm - Modular)	77300-01
Gear Only (600 rpm)	07553-09
Gear Service Kit (100 rpm)	07553-08
Footswitch w/ DB-15 male	07595-42
Connector DB-15 male	07595-52
Dispensing Wand DB-15 male	07595-60
Hand-held remote control (NEMA)*	07592-83
Footswitch (NEMA)*	07595-43
Remote control cable, 25 ft. (NEMA)*	77300-32
* (For 77301-30 <u>only</u> .)	

SPECIFICATIONS

Output:

Speed:

7523-60, 7550-30, 77301-20, -30	10 to 600 r/min
7523-70, 7550-50	1.6 to 100 r/min

Torque output, Maximum:

7523-60, 7550-30, 77301-20, -30	180 oz-in (13 kg•cm)
7523-70, 7550-50	360 oz-in (26 kg•cm)

Speed regulation:

Line	±0.25% F.S.
Load	±0.25% F.S.
Drift	±0.25% F.S.

Display:

Four-digit, seven-segment LED

Remote outputs:

All units	Voltage speed output (0–10V DC @ 1 k Ω min)
All units	Current speed output (0–20 mA or 4–20 mA @ 0–600 Ω)
7550-30, -50	RS-232C
7550-30, -50	AUX 1 and 2 OUT (Contact closure 5A @ 115/230 Vrms)
7523-60, 7550-30, 77301-20, -30	Tach output (TTL, 100 to 6000 Hz, 50% duty cycle, 10 Hz/rpm)
7523-70, 7550-50	Tach output (TTL, 16 to 1000 Hz, 50% duty cycle, 10 Hz/rpm)
All units	Motor running output (N.O. & N.C. contact closure, 1A @ 28V AC/DC)

Input:

Supply voltage limits:

Dual voltage—Automatically selected
90 to 130 Vrms @ 50/60 Hz, or
200 to 260 Vrms @ 50/60 Hz

Current, max.:

2.2A @ 115 Vrms, or
1.1A @ 230 Vrms

Remote Inputs:	
All units	STOP/START, CW/CCW, PRIME (Contact closure)
All units	Voltage input (0–10V DC @ 10 k Ω)
All units	Current input (0–20 mA or 4–20 mA @ 250 Ω)
7550-30, -50	RS-232C
7550-30, -50	AUX IN (Contact closure)
Construction:	
Dimensions (L \times W \times H):	
7523-60, -70, 7550-30, -50	11 1/2 in \times 7 11/16 in \times 7 3/16 in (292 \times 196 \times 182 mm)
77301-22	9 3/4 in \times 9 3/16 in \times 5 1/16 in (248 \times 233 \times 129 mm)
77301-23	9 in \times 11 in \times 4 1/2 in (229 \times 279 \times 114 mm)
77301-21	8 7/8 in \times 3 13/16 in \times 4 3/4 in (226 \times 97 \times 120 mm)
Weight:	
7523-60, -70, 7550-30, -50	15 lb (6.8 kg)
77301-22	4.0 lb (1.8 kg)
77301-23	9.4 lb (4.3 kg)
77301-21	9.5 lb (4.3 kg)
Enclosure Rating:	
7523-60, -70, 7550-30, -50	IP 23 per IEC 529
77301-22	IP 22 per IEC 529
77301-23	IP 56 (NEMA 4) per IEC 529
77301-21	IP 56 (NEMA 4) per IEC 529
Environment:	
Temperature, Operating:	0° to 40°C (32° to 104°F)
Temperature, Storage:	–25° to 65°C (–13° to 149°F)
Humidity (non-condensing):	10% to 90%
Altitude:	Less than 2000 m
Pollution Degree:	
7523-60, -70, 7550-30, -50, 77301-20	Pollution Degree 2 (Indoor use—lab, office)
77301-30	Pollution Degree 3 (Sheltered locations)
Chemical Resistance:	Exposed material is aluminum, ABS plastic and vinyl
Compliance:	UL508C, CSA C22.2, No. 14 (For CE Mark): EN61010-1 (EU Low Voltage Directive) and EN61326 (EU EMC Directive)

WARRANTY

Use only MASTERFLEX precision tubing with MASTERFLEX pumps to ensure optimum performance. Use of other tubing may void applicable warranties.

The Manufacturer warrants this product to be free from significant deviations from published specifications. If repair or adjustment is necessary within the warranty period, the problem will be corrected at no charge if it is not due to misuse or abuse on your part, as determined by the Manufacturer. Repair costs outside the warranty period, or those resulting from product misuse or abuse, may be invoiced to you.

The warranty period for this product is noted on the Warranty Card.

PRODUCT RETURN

To limit charges and delays, contact the seller or Manufacturer for authorization and shipping instructions before returning the product, either within or outside of the warranty period. When returning the product, please state the reason for the return. For your protection, pack the product carefully and insure it against possible damage or loss. Any damages resulting from improper packaging are your responsibility.

TECHNICAL ASSISTANCE

If you have any questions about the use of this product, contact the Manufacturer or authorized seller.

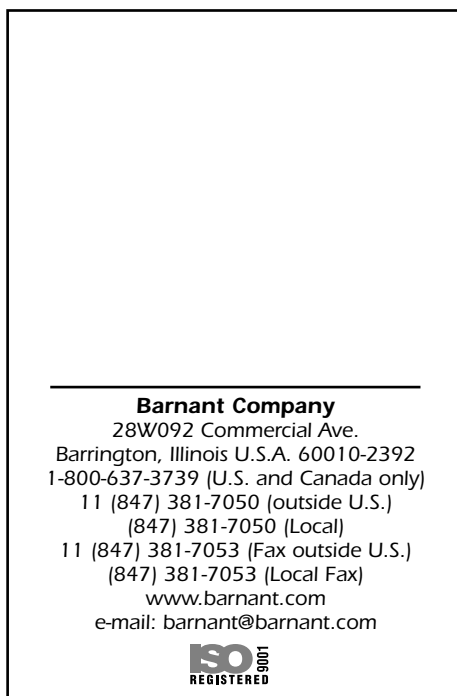

APPENDIX A PUMP DRIVE COMMUNICATION SPECIFICATION

1.0 - LINKABLE INSTRUMENT NETWORK

The Linkable Instrument Network is a serial communication system consisting of a control computer with one RS-232C port and one or more satellite units. A satellite unit can be a pump drive (7550-30, -50), mixer controller (50003-00, -05), or any future product that conforms to the communications protocol defined in this description. This description describes all the information needed to communicate with a pump drive. Since much of this information applies to other products, the term "satellite unit" will be used as a generic term for all devices compatible with the Linkable Instrument Network. The term "pump drive" will be used when the information applies only to MASTERFLEX Computerized Drives (7550-30, -50).

Drives (7550-30, -50)

All communications between the control computer and satellite units is based on a pseudo daisy-chain principle. The transmission line of the control computer will pass through the input and output buffers in each of the satellite units. Each satellite unit will have the ability to turn the buffers on and off to block communications from other units below it in the daisy-chain. The output of the control computer would pass through each of the pump drives without software assistance from the pump drive. All Pump Drives in the daisy-chain must be powered up to enable communications with all drives.

The receive line of the control computer will originate in the transmitter of the last satellite in the chain. It will also be double buffered through each satellite. Each of the pump drives will have the ability to turn off its input receive line and place its own transmitter on the receive line to the control computer.

A third line, the Request To Send (RTS) will be a similarly buffered line. Each satellite will have the ability to set this line to signal the computer its request to send.

The maximum number of satellites is limited to 25 by the Linkable Instrument Network software to minimize communication time. However, up to 89 satellites could be controlled by a single RS-232C port using custom software since satellite units can be assigned any number from 01 to 89.

1.1 - SERIAL CONNECTIONS

The 7550 Digital PWM BLDC Drives communicate with each other and a PC via a standard DB-9 modem cable (Cat. #22050-54). Older satellite units have a dual 6 position modular phone jack labeled "IN" and "OUT". Pin 1 on both jacks is located towards the top of the drive. The control computer will have a standard DB-25 plug as found on most RS-232C connections. The DB-9 "AT" type connector can also be used with the DB-9 to DB-25 adapter included with 7550-64 Computer to Pump cable assembly.

"IN" JACK

- Pin 1 - No connection
- Pin 2 - Receive signal from the computer
- Pin 3 - Transmit signal to the computer
- Pin 4 - Ground
- Pin 5 - Request to send (RTS) to the computer
- Pin 6 - No connection

"OUT" JACK

- Pin 1 - No connection
- Pin 2 - Request to send (RTS) from the next satellite
- Pin 3 - Ground
- Pin 4 - Receive signal from the next satellite
- Pin 5 - Transmit signal to the next satellite
- Pin 6 - No connection

DB-25 PLUG ON CONTROL COMPUTER

- Pin 2 - Transmitted data to satellite
- Pin 3 - Received data from satellite
- Pin 5 - Clear to send—RTS from satellite
- Pin 7 - Ground

DB-9 PLUG "AT type" ON CONTROL COMPUTER (DTE) AND SATELLITE

- Pin 3 - Transmitted data to satellite
- Pin 2 - Received data from satellite
- Pin 8 - Clear to send—RTS from satellite
- Pin 5 - Ground

DB-9 SOCKET ON SATELLITE (DCE)

- Pin 3 - Receive signal from the computer
- Pin 2 - Transmit signal to the computer
- Pin 5 - Ground
- Pin 8 - Request to send—(RTS) to the computer

The serial lines between units will be passed from unit to unit by a hardware buffer on the input and connecting it directly to the output driver through a hardware gate. This way any output only sees one input load. If power is turned off on any pump drive, all drives below it in the daisy-chain cannot communicate.

1.2 - SERIAL DATA FORMAT

The serial data format is full duplex (simultaneously transmit and receive), 1 start bit, 7 data bits, one odd parity bit, and one stop bit at 4800 bits per second. All data transmitted will consist of characters from the standard ASCII character set.

Note: Odd parity is defined such that the sum of the eight individual bits is an odd number (1, 3, 5 or 7).

1.3 - SERIAL PROTOCOL

All transmissions originate or are requested by the control computer (master). It may issue commands directly and it may request that the satellites report. When asked to report, the satellite would send the data requested. Should a satellite require communication with the computer, it has the ability to operate the request to send (RTS) line. Upon receiving the request, the computer would respond via the serial line (section 1.11).

1.4 - START UP SEQUENCE

Normal start up would consist of turning on all the satellite units first and then the control computer. Each satellite will enable its receive and transmit buffers and activate its RTS line. The control computer would then send the enquire <ENQ> command in response to the active RTS line. Upon receiving the <ENQ> command, all satellites with an active RTS line would disable its receive and transmit buffers to the satellites below it in the daisy-chain. Next the pump drives would respond with one of the following strings depending on its model number and version.

<STX>P?0<CR> = 600 RPM 7550 -30
<STX>P?2<CR> = 100 RPM 7550 -50

The control computer would only see the response from the first satellite in the chain since communications with the others is now blocked. The control computer would then send back <STX>Pnn<CR> with nn being a number starting with 01 for the first satellite and incrementing for each satellite up to 25 maximum. If the pump drive receives the data without errors it will perform the following steps:

1. Deactivate its RTS line and enable the receive buffers to the next satellite.
2. Send an <ACK> to the control computer.
3. Enable the transmit buffer from the next satellite within 100 milliseconds after the last byte has been sent.
4. Put a P and the satellite number received in the first 3 positions on the satellite display.

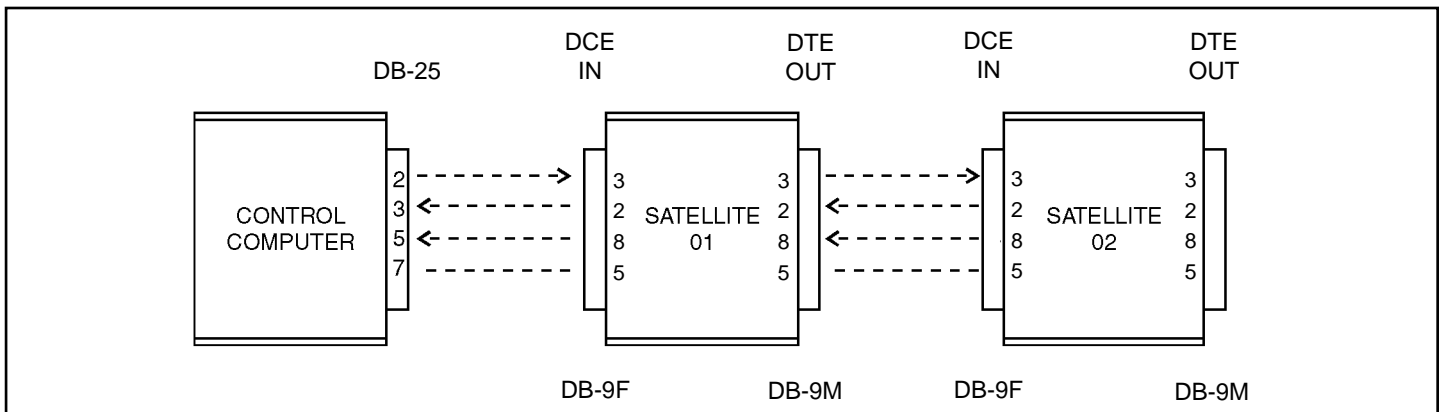

Figure A1 - Serial daisy-chain connections

After the control computer receives the <ACK> it will see the RTS from the next satellite and again issue the <ENQ> command. The above process will be repeated until all satellites are numbered.

If a satellite does not receive valid data from the control computer or detects a transmission error, it will send a <NAK>. When the control computer receives the <NAK> it will resend the <STX>Pnn<CR> to the satellite. Section 1.10 on error handling describes the maximum retries the control computer will perform.

If a satellite is turned on after all the other satellites have been numbered, it will be numbered the same as described above with the next available number if no commands have been sent to the other satellites. If commands have been issued, the satellite is assigned a temporary number starting with 89 and decrementing for each subsequent satellite. This will cause the satellite to release its RTS so normal communication can proceed. The operator will be alerted to the condition that another satellite has come on-line and needs to be numbered. The operator will then be able to assign the new satellites a number so that they will appear correctly in the system. The control computer will use the following commands to renumber a satellite:

<STX>PooUnn<CR>

The oo is the old satellite number and nn the new number.

If a satellite is requesting to be numbered and the control computer has already issued 25 satellite numbers, the control computer will assign the satellite the number 89 as described in the preceding paragraph and alert the operator to the situation.

If a satellite is powered down after it has been numbered, it will be treated as a new unit as described above when it is powered up again.

1.5 - REMOTE/ LOCAL OPERATION

Once a satellite is in the remote mode, it can be returned to local mode using the control computer and the "L" command. If the control computer program is no longer running, the satellite can be powered off and then on to return it to local operation. If the "L" command is used, the satellite will retain its assigned number and respond to request commands from the control computer but ignore control commands.

1.6 - COMMAND FORMAT

Most commands from the control computer are preceded with the start of text <STX> character (02 hex), a satellite identification letter (P for Pump, M for mixer) and a two digit satellite number (01 through 89). Numbers 00 and 90 through 99 are reserved for special cases. When the same command is to be executed by all pump drives, 99 is sent for the satellite number. After the command character is the parameter field which varies in size from zero characters to 32 depending on the command. A carriage return <CR>, (0D hex) is used to indicate the end of a command string. (Note, the exceptions to this computer issued command format are <ENQ>, <ACK> and <NAK>.) See Figure A2.

More than one command can be put in a command string as shown following:

<STX>P09S+0500.0V08255.37G <CR>

The above multiple command string example would set the speed at pump satellite 09 to 500.0 RPM,

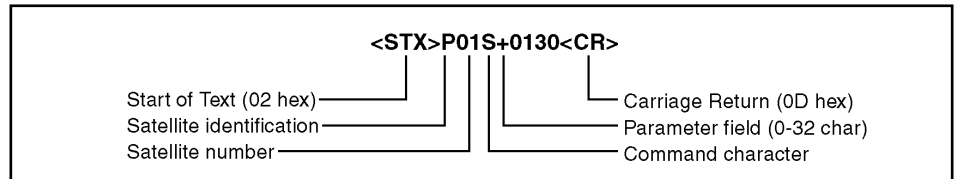

Figure A2

clockwise direction, set 8255.37 revolutions and start the drive. The maximum number of characters allowed in one pump drive string is 38, including <STX>, Pnn and <CR>.

1.6.1 - Command Features

1. INITIALIZING

Before a pump drive can be controlled, it must first be numbered. If any command is issued before this is done, the satellite will not respond.

2. SETTING SPEED

If a SPEED command is issued after the speed has already been set, the new speed will be used. If the pump drive is running and a different direction is sent to the pump, the pump will send back a <NAK>. A halt command must first be issued before the direction can be reversed.

3. SETTING REVOLUTIONS

When "Revolutions To Go" are set with the V command, they are added to the total revolutions to go counter. The maximum this counter can be is 99999.99. If a revolutions to go count is sent to the pump drive which would cause the counter to over flow past 99999.99, the pump drive will not add the value to its revolutions to go counter and will send the control computer a <NAK>. The revolutions to go counter can be set to zero by using the Z command, which will also cause the pump to stop if it is running when the Z command is received.

1.7 - CONTROL COMPUTER PARAMETER FIELDS

The parameter field sent by the control computer is variable in length. The control computer will have the option of using leading zeroes, leading spaces, or no padding at all. For example, if 200 revolutions was to be sent with the V command, the following

list of parameters would all be accepted by the satellite as valid:

(s = space) 00200.00
 ss200.00
 sss200.00
 sssss200
 200.00
 200.0
 200

1.7.1 - Satellite Data Fields

Any data that a satellite sends to the control computer will have a fixed number of characters which is determined by the command. For example, if the control computer requested the cumulative volume, it would always receive 10 characters representing the cumulative volume (0000000.00 to 9999999.99).

1.8 - PUMP DRIVE STATUS REQUEST

When the control computer requests status from the pump drive (I command or <ENQ>), the satellite will respond with the following status information (Figure A3):

Note: "Pump not numbered" is also a pump status but it is not included in the pump status byte since this condition is handled separately using the P?x (see section 1.4).

When the satellite sends the status information, any status conditions that are latched by the satellite will be cleared by the control computer sending an <ACK>Pnn<CR>. If the satellite receives the I command again, it will respond with the same status information.

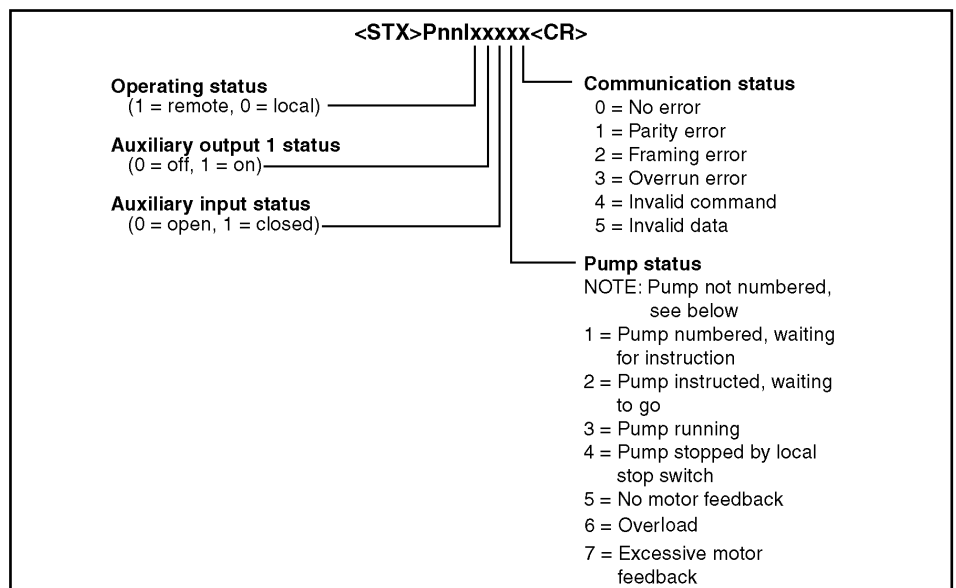

Figure A3

1.9 - SATELLITE RESPONSE

When the pump satellite correctly receives a command, it will send back an <ACK> (06 hex) if it was not an all pumps command (P99). If data has to be sent back to the master in response to the command, it will be sent as shown in Table 2. If the satellite detected an error while receiving a command, it will respond with a <NAK>.

1.10 - ERROR HANDLING

Depending on the error code received from the satellite, the control computer would have to take appropriate action to try to eliminate the error condition. Communication errors of type 1, 2 or 3 indicate a hardware type error: noisy communication lines, bad connection, glitches or circuit failure. Communication error codes 4 or 5 could be hardware errors as previously described or software errors caused by incorrect commands or data being sent by the control computer. For hardware type errors the control computer would try sending the same command to see if the problem was only momentary. If an error code is returned four times in a row or if there is no response at all, the control computer would abort trying to send the command and notify the operator of the type of error.

If a satellite does not respond at all, the control computer can assume one of the following:

1. If all other satellites connected after the satellite in question also don't respond, the communication link is broken at that point or the satellite is defective.
2. If all other satellites respond, the unresponding satellite is either turned off, removed from the loop, or defective.

1.11 - SATELLITE REQUEST TO SEND

When a satellite wants to communicate with the control computer, it will turn on its request to send (RTS) line and then wait for the (ENQ) enquire character (05 hex) from the control computer. The following list shows the possible conditions that would cause the pump drive to activate its RTS line.

1. Auxiliary input status change.
2. Motor error.
3. Stop key pressed at satellite while in the remote mode.
4. Programmed volume was reached.
5. Power up.

The following is the sequence of events for when RTS is activated by a pump drive:

1. Satellite enables RTS line.
2. When control computer detects RTS, it will transmit the (ENQ) enquire command (05 hex) after it completes any communications it may be in the process of doing.
3. When the satellite that has its RTS line enabled receives the <ENQ> it will disable its RS-232C buffers to block the other satellites below it in the daisy-chain from communicating with the control computer. This would give the satellite closest to the control computer the highest priority if more than one satellite enabled its RTS line at the same time.
4. Next the pump drive will send the response from the I command as shown in section 1.8.
5. If the control computer received the satellite response without any errors (parity, overrun etc.)

it will send an acknowledge <ACK>Pnn<CR> which will cause the satellite to release its RTS line and enable the RS-232C buffers allowing the satellites below it in the daisy-chain to communicate. If the control computer detected any error during the transmission it would send the enquire (ENQ) again which would cause the satellite to re-send its response. The control computer will retry a maximum of four times before aborting and reporting the error to the operator.

6. If more than one satellite has its RTS line enabled, the control computer would see only the response from the satellite closest to it. After the closest satellite sent its response and released the RTS line, the control computer would see the RTS of the other satellite and again issue the enquire command which would allow the next satellite with RTS active to respond.
7. If a satellite was responding to an enquire command and another satellite with higher priority also started to respond, cutting off the first responding satellite, the control computer would receive invalid data and get some type of error (parity or framing). This would cause the control computer to resend the enquire, but this time only the higher priority satellite would respond since the communications with the lower satellites is blocked.

COMMAND CHARACTERS FROM CONTROL COMPUTER TO PUMP	PARAMETER FIELD
A Request auxiliary input status	none
B Control auxiliary outputs when G command executed	xy, x = aux1, y = aux2, 0 = off, 1 = on
C Request cumulative revolution counter	none
E Request revolutions to go	none
G Go Turn pump on and auxiliary output if preset	none = run for number of revolutions set by V command 0 = continuous run until Halt command
H Halt (turn pump off)	none
I Request status data	none
K Request front panel switch pressed since last K command	none
L Enable local operation	none
O Control auxiliary outputs immediately without affecting drive	xy, x = aux1, y = aux2, 0 = off, 1 = on
R Enable remote operation	none
S Set motor direction and RPM	+xxx.x, -xxx.x, +xxxx, -xxxx + = CW, -=CCW
S Request motor direction & RPM	none
U Change satellite number	nn new satellite number
V Set number of revolutions to run	xxxxx.xx
Z Zero revolutions to go counter	none
Z Zero cumulative revolutions	0
<CAN> Terminates line of data up to and including STX (used primarily for keyboard input)	none
<ENQ> Enquire which satellite has activated its RTS line	none

Table 1 - Pump satellite commands

CONTROL COMPUTER COMMAND STRING	PUMP DRIVE RESPONSE
<STX>PnnA<CR>	<STX>Ax<CR> x: 0=open, 1=closed
<STX>PnnBxy<CR> xy: 0 = off, 1 = on x = aux1, y = aux2	<ACK> or none if P99
<STX>PnnC<CR>	<STX>Cxxxxxx.xx<CR> max revolutions = 9,999,999.99
<STX>PnnE<CR>	<STX>Exxxxx.xx <CR> x : revolutions to go (99,999.99 max) (-xxxx.xx if drive overshoots)
<STX>PnnG<CR>	<ACK> or none if P99
<STX>PnnH<CR>	<ACK> or none if P99
<STX>PnnI<CR>	<STX>PnnIxxxx<CR> (see section 1.8)
<STX>PnnK<CR>	<STX>Kx<CR> (see section 1.12)
<STX>PnnL<CR>	<ACK> or none if P99
<STX>PnnOxy<CR> xy: 0 = off, 1 = on x = aux1, y = aux2	<ACK> or none if P99
<STX>PnnR<CR>	<ACK> or none if P99
<STX>PnnS+0130<CR> or	<ACK> or none if P99
<STX>PnnS+0130.0<CR>	<ACK> or none if P99
<STX>PnnS<CR>	<STX>S+0432.9<CR>
<STX>PnnUnn<CR> nn = 01, 02, 03...87, 88, 89	<ACK>
<STX>PnnVxxxxx.xx<CR> V max = 99999.99	<ACK> or none if P99
<STX>PnnZ<CR>	<ACK> or none if P99
<STX>PnnZ0<CR>	<ACK> or none if P99
<CAN>	<ACK>
<ENQ>	<STX>P?x<CR> (on pump power up) <STX>PnnIxxxx<CR> (see section 1.8)

Table 2 - Sample pump commands and responses

1.12 - FRONT PANEL SWITCHES

The control computer can read the satellite's front panel switches by issuing the K command. The satellite will respond with one character indicating the last switch pressed since the last K command was acknowledged. If more than one key was pressed, only the last one pressed is indicated. After the control computer receives the satellite's switch status, it must send an <ACK>Pnn<CR> to inform the satellite it can reset the switch status to no key pressed. Table 3 following shows the character returned by the K command and the corresponding switch for pump units.

0 = No key pressed	6 = Dir
1 = Stop/Start	7 = Size
2 = Prime	8 = Flow rate
3 = Mode	9 = Down arrow
4 = Dispense	A = Up arrow
5 = Cal	

Table 3 - K command key codes for pump drives

1.13 - ASCII CONTROL CHARACTERS USED

DECIMAL	HEX	CHARACTER	
2	02	STX Start of Text	(CTRL - B)
6	06	ACK Acknowledge	(CTRL - F)
5	05	ENQ Enquire	(CTRL - E)
13	0D	CR Carriage Return	(CTRL - M) (CR)
21	15	NAK Negative Acknowledge	(CTRL - U)
24	18	CAN Cancel	(CTRL - X)

Table 4 - ASCII control codes used